

Insulation installation

Installing insulation in a new dwelling or adding insulation to an existing one can make a significant difference to the comfort and energy performance of the home, but it is vital that the insulation is put in correctly. Read the article in conjunction with *Insulation* to find out how to install insulation in various types of construction and useful tips for achieving the results you want.

Under the Building Code of Australia (BCA), the resistance of a building fabric to heat flow, expressed as 'total R-value', varies depending on climate zone and the building site's height above the Australian Height Datum. Ensure you comply with the BCA requirements for energy efficiency of building fabric.

Installation tips

To install insulation without compromising its effectiveness, you need to consider a range of issues: thermal bridging, vapour barriers, ventilation, air gaps, and physical handling of the different types of insulation.

Thermal bridging

The building frame can act as a thermal bridge, particularly in cold climates, conducting heat and allowing it to bypass otherwise effective insulation. Metal framing is a particular problem because of its high conductivity. The presence of the frame reduces the overall insulation value, as the frame can constitute up to 15% of the wall, ceiling or floor surface. To help overcome the effect of thermal bridging:

- install polystyrene isolating strips between the metal frame and cladding, which must be at least 12mm thick with an R-value of 0.2
- fix bulk insulation, such as polystyrene boards, over the external or internal surface of the frame.

Vapour barriers

Vapour barriers include polythene sheeting, reflective foil, foil backed plasterboard and well maintained water-resistant painted surfaces. Water-resistant insulation, such as polystyrene, can also act as a vapour barrier. Tape or glue all joints in vapour barriers to keep out moisture.

Use vapour barriers to protect from condensation:

- in high humid (tropical) climates

- in cool climates where the difference between indoor and outdoor temperature is significant
- in roof spaces with a low ventilation rate (e.g. cathedral or raked ceilings)
- in situations where high amounts of vapour are generated and not exhausted
- on the underside of metal roofing, to minimise the likelihood of condensation and corrosion.

Install vapour barriers on the warm side of the insulation:

- in cold climates, on the inside of the insulation (directly above the ceiling lining and next to the internal wall lining)
- in warm climates, on the outside of the insulation.



Installing wall insulation.

Roof ventilation

Ventilate the roof space where possible to allow built-up heat to dissipate. Even in cooler climates a minimal amount of ventilation is desirable to allow built-up moisture to escape. Air gaps along the ridgeline or between tiles often provide sufficient ventilation. Gable or eaves vents may also be used.

Ventilated roof spaces in high humid (tropical) climates under metal roofing can result in excessive condensation within the roof space at night. You can prevent condensation dripping off the underside of metal roofing onto the ceiling by installing reflective foil sarking similar to that used under roof tiles, or using a foil-backed building blanket (anti-condensation blanket) under the metal roof, or closing the vents at night to prevent night air from entering the roof space.

Passive design

Insulation installation

In bushfire prone areas, cover any openings with fine stainless steel mesh to prevent cinders from entering the roof space. Keep roof spaces weather-tight and vermin proof.

Gaps

Avoid gaps in all types of insulation. Even a small gap can greatly reduce the insulating value. Fit batts snugly and don't leave gaps around ducts and pipes. Tape up holes and joins in reflective insulation. Make sure the ends of multi-cell and concertina foils are well sealed, and ensure that corners of walls, ceilings and floors are properly insulated as these are areas where heat leaks most often occur.

For safety reasons, minimum clearances must be left around hot objects, such as flues from fires, recessed downlights and their transformers (see 'Health and safety tips' below).

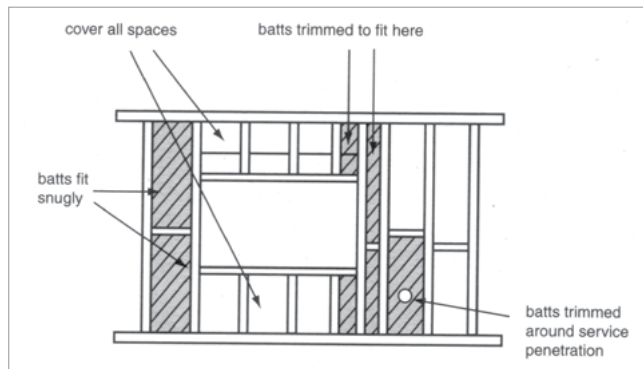

Wall frame with insulation.

Wall insulation must butt into door and window frames. In cold climates, metal frames around glazing should have thermal breaks to reduce heat loss. (see *Glazing*)

Insulate internal walls between the house and uninsulated spaces such as garages and storerooms.

Bulk insulation

Do not compress bulk insulation as this reduces its effectiveness. Ensure there is sufficient space for the insulation to retain its normal thickness.

Keep moisture away from bulk insulation, or its performance will be reduced (water resistant types are an exception). Use a vapour barrier where there is a risk of condensation.

Restrain bulk insulation in cavities so it does not come into contact with the porous outer skin of the wall. This can be done with perforated reflective foil laminate (RFL), a non-corrosive wire or nylon fishing line.

Cavity fill insulation (loose-fill or injected foam) is particularly useful for insulating existing cavity walls. Check that your local building codes permit the use of cavity fill insulation.

Potential problems to be aware of include the overheating of electrical cables, dampness (if the insulation is absorbent) and moisture transfer across the cavity by capillary action. Injected foams can also cause bowing of the walls in some cases.

Loose-fill insulation should not be used in excessively draughty roof spaces or ceilings with a slope of 25° or more. In other applications, keep the density of the insulation consistent to avoid reducing the R-value. Note that loose-fill insulation may settle by as much as 25% over time. Ask your contractor for a guaranteed 'settled R-value'.

Reflective insulation

Maintain an air space of at least 25mm next to the shiny surface of reflective insulation. If this is not done the insulating properties are reduced.

Dust settling on the reflective surface of insulation greatly reduces its performance. Face reflective surfaces downwards or keep them vertical.

Use perforated reflective foil in walls when building with porous materials. The perforations prevent water droplets from penetrating but allow vapour through so that the insulation can dry if it does somehow get wet. This prevents rotting behind weatherboards, for example.

Reflective foil insulation should not be placed on top of ceilings or ceiling joists, nor under floors, as it is electrically conductive. Any such insulation must also be secured with non-conductive staples.



Reflective foil insulation.

Health and safety tips

Wear protective clothing, gloves and a face mask when installing glass wool, mineral wool or cellulose fibre insulation. These materials can cause short term irritation to skin, eyes and the upper respiratory tract. It is good practice to always wear protective equipment when working in dusty roof spaces.

Wear adequate eye protection when installing reflective insulation, as it can give off a painful glare, and be aware of the increased risk of sunburn.

Insulation materials containing reflective foil must be kept clear of electrical wiring and fittings, and should not be secured using metal staples.

Electrical wiring must be appropriately sized or it may overheat when covered by insulation. Have it inspected by a licensed electrician.

Allow clearance around hot flues, exhaust fans, appliances and fittings that penetrate the ceiling to the manufacturer's installation instructions.

Clearances around downlights

Ceiling fires have increased significantly with the more common use of downlights that penetrate the ceiling. Take care to maintain minimum clearances around downlights and ensure that transformers are not underneath the insulation. Wherever possible avoid using recessed light fittings as they also shed a great deal of heat through the gaps required in the surrounding ceiling insulation.

Recessed lights and their auxiliary equipment should be installed in a manner designed to prevent the light and equipment overheating and igniting surrounding combustible materials. Particular notice should be taken of manufacturers' installation instructions for lights that include warnings about covering them with insulation or display the following symbol meaning 'Do Not Cover'.

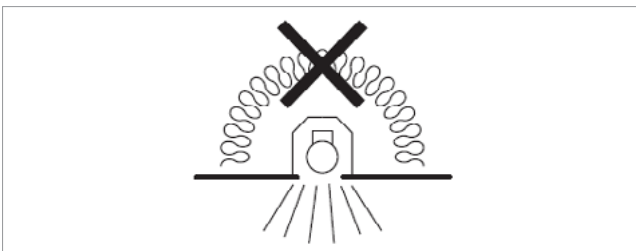

'Do not cover' symbol.

The heat generated from recessed lights needs to be dissipated in order to prevent damage to the light or to adjacent materials. In accordance with AS 3999, Thermal insulation of dwellings – bulk insulation – installation requirements, this can be achieved by:

- installing lights certified by the manufacturer as being suitable for operation in contact with combustible materials or in contact with or covered by insulation

- installing lights in combination with a fire safety barrier tested and classified in compliance with AS/NZS 5110, Recessed lighting barrier standard, or
- separating the light from insulation and combustible building elements.

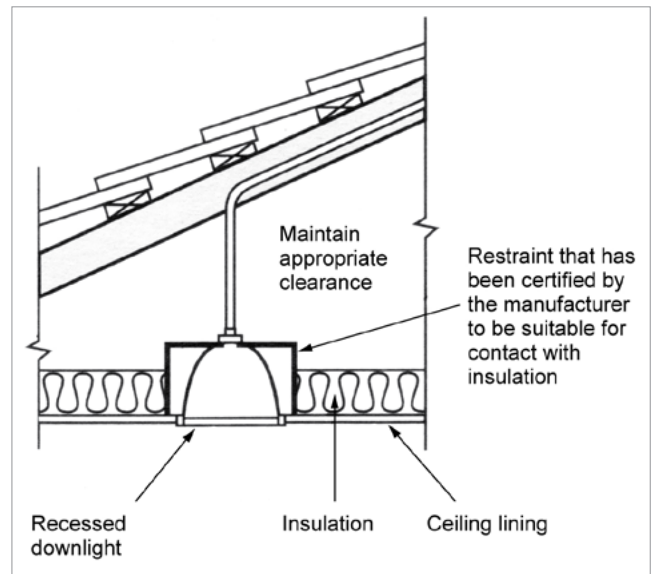

Safe installation of ceiling lighting.

For recessed light fittings, where the manufacturer's installation instructions do not provide information on required clearances, the light fitting can be installed using a suitable Australian Standards approved enclosure for electrical and fire safety. Where barriers are not used, allow a minimum clearance of 200mm above and to either side of any structural member, with a 50mm gap for lighting transformers. Refer to AS/NZS 3000: 2007 electrical installation (wiring rules) for more detailed information.

Where the ceiling insulation is loose fill or not fixed in position, or there is the possibility of extraneous combustible material such as leaves and vermin debris getting into the roof space, maintain clearances by providing a barrier complying with AS/NZS 5110 or a guard or collar constructed of fire-resistant material.

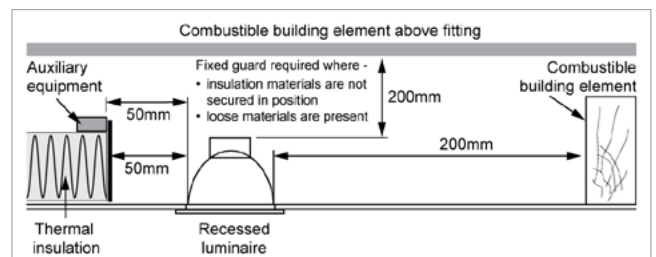

Source: Adapted from AS/NZS 3000:2007 Figure 4.7 – reproduced with permission from SAI Global

Default minimum clearance for recessed lights.

Passive design

Insulation installation

Where recessed lights are installed in an accessible roof space, a permanent and legible warning sign must be installed in the roof space adjacent to the access panel in a position that is visible to a person entering the space. The sign must comply with AS 1319, Safety signs for the occupational environment, and contain the words shown here.



Warning sign to be installed in accessible roof spaces containing recessed lights.

Installation details

'Total R-values' describe the total resistance to heat flow provided by a roof and ceiling assembly, a wall or a floor. These values are calculated from the resistances of each component, including the insulation.

Total R-values are the best indicator of performance, as they show how insulation performs within the building envelope. Total R-values are used when calculating thermal efficiency ratings.

To estimate the total R-value:

- Consult the ICANZ Insulation Handbook, Part 1, Thermal Performance (icanz.org.au) to find the construction type that relates to your situation (e.g. pitched tiled roof with flat ceiling and an unventilated roof space).
- Calculate the total thermal resistance of the building components of your construction type.
- Add the material or system value of insulation you are installing to give you an approximate total R-value.

For example, adding bulk insulation with a material R-value of 2.5 increases both the up and down total R-values by around 2.5, as long as the material is not compressed.

Adding reflective insulation with a system R-value of 1.7 up, 3.0 down, increases the total up and down R-values by those amounts, providing the insulation is installed as specified with air gaps.

This method provides a useful estimate, but many factors can reduce the total R-value. They include thermal bridging, compression of bulk insulation, dust settling on reflective insulation and the lack of a suitable air gap for reflective surfaces.

Note: Revised standards now in preparation (2013) require all reflective insulation to have an anti-glare coating, which will reduce the thermal performance of the upper surface.

The total thermal resistance of each construction type has been calculated using information from the Australian Standards.

Total R-values for roofs, ceilings and floors are expressed as up and down values. Thermal resistance to heat flowing up and heat flowing down can vary significantly. Total R-values for walls are expressed as a single figure, as heat flow in and out through walls does not necessarily correlate to heat flow up and down.

Roof and ceiling insulation

Installing roof and ceiling insulation can save up to 45% on heating and cooling energy.

Installing roof and ceiling insulation can save up to 45% on heating and cooling energy.

Pitched roofs with flat ceilings

This is the most common type of construction and the easiest to insulate. The BCA specifies different insulation requirements for roofs and ceilings according to the climate zone.

Roof

A second layer of RFL (either sarking or foil batts) beneath the roof increases resistance to radiant heat. This may be useful in hot climates. Ensure that there is at least a 25mm gap between reflective surfaces and other materials. Place RFL sarking directly under the roofing material between the battens and the rafters with the shiny side facing down.

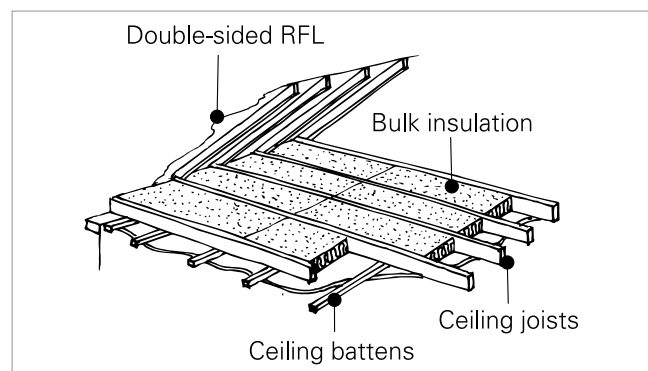

Pitched roof with flat ceiling.

Ceiling

Place ceiling insulation between the joists. Suitable bulk insulation includes batts, loose-fill and polystyrene boards. In alpine climates two layers of bulk insulation may be installed to increase thermal performance, one between the joists and the second on top.

There are hazards related to covering ceiling joists with insulation, e.g. safe places to walk cannot be identified when accessing the roof space. If insulation is removed each time the roof space is accessed it must be reinstalled in accordance with the Australian Standard.

Suitable reflective insulation includes multi-cell batts, which should be placed between ceiling joists. Install insulation strictly in accordance with manufacturer's instructions. Failure to do so can significantly reduce insulation values.

Ceilings that follow the roof line

These include sloping ceilings, cathedral ceilings, vaulted ceilings, and flat or skillion roofs, where there is no accessible roof space. Design ceilings with enough space to accommodate adequate insulation, including any necessary air gaps.

Ceilings with concealed rafters are easier to insulate and should be considered in preference to ceilings with exposed rafters. Ceilings with exposed rafters require insulation products with a higher R-value per unit thickness due to space limitations within the ceiling.

Consult the insulation manufacturer about installation clearances. As a rough guide, minimum clearance heights for ceilings that are parallel with the roof are:

- R3.0 bulk batts: 130mm
- R3.0 polystyrene boards: 85mm.

Use sarking or foil backed insulation under metal roofs, making sure that there is at least a 25mm gap below the reflective surface of the insulation. Do not use foil backed insulation under tile roofs.

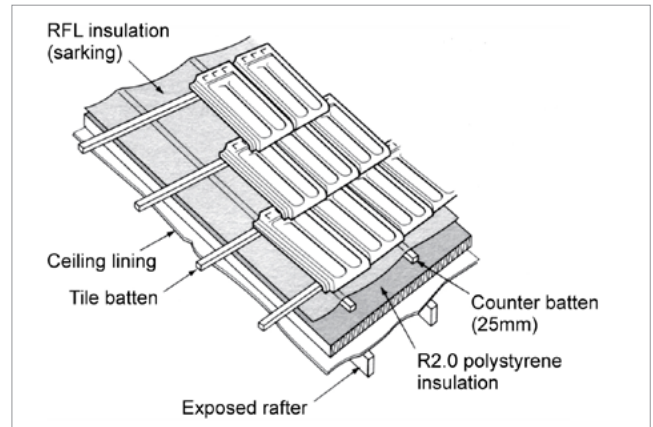

Exposed rafters with polystyrene insulation. The counter battens must be secured to the rafters with appropriate fasteners to prevent roof failure in storms or high winds.

Suitable bulk insulation includes polystyrene boards and batts. Suitable reflective insulation includes multi-cell and concertina-type batts.

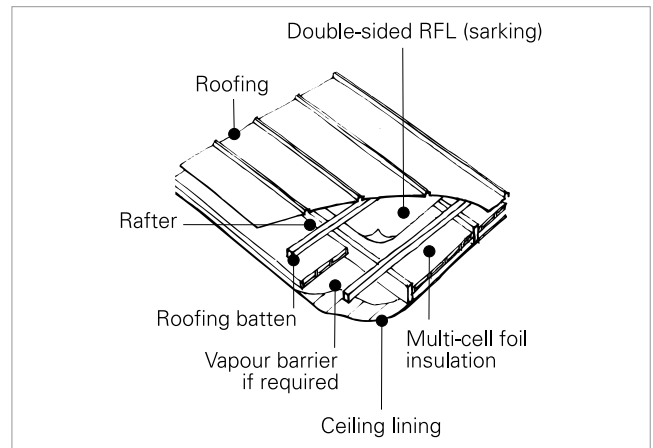

Exposed rafter with multi-cell foil insulation.

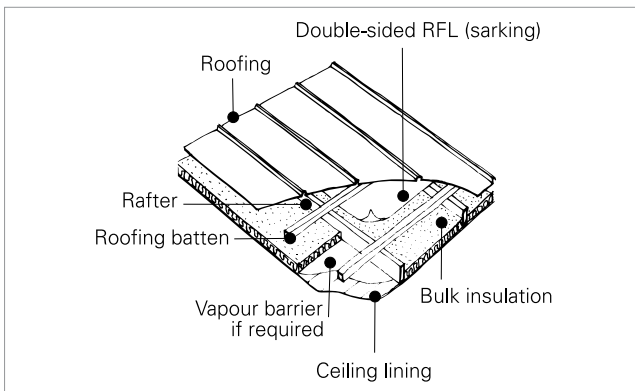

Concealed rafters.

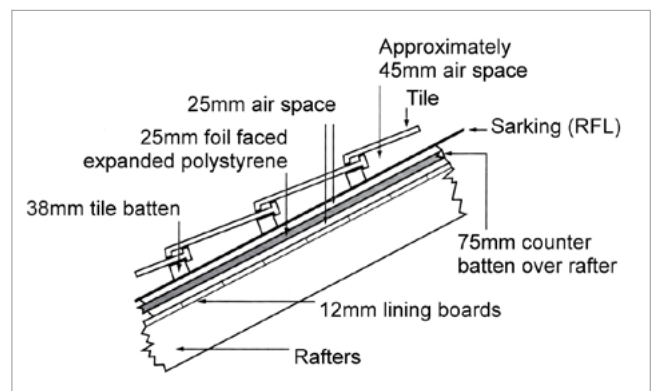

Exposed rafters require minimum batten height of 75mm.

Passive design

Insulation installation

Suitable composite insulation includes foil faced polystyrene boards. If rafters are exposed, the minimum batten height is 75mm to allow for two 25mm reflective air spaces either side of the boards. Using 25mm foil faced polystyrene boards and RFL sarking gives a total R-value of around 1.7 up, 2.9 down. If higher R-values are required then larger batten heights will be required to accommodate thicker insulation.

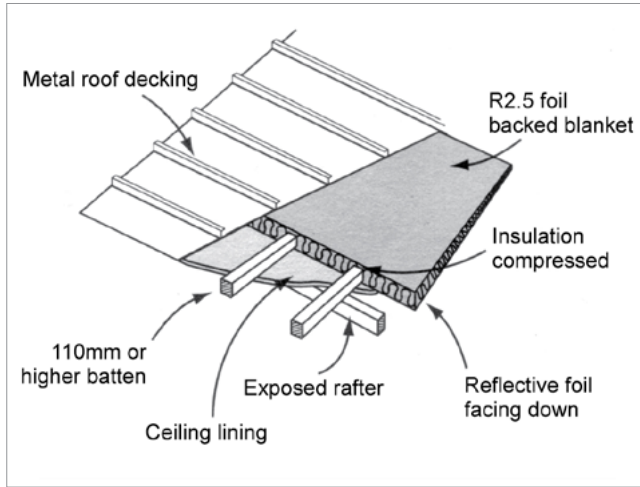

Metal roof decking.

Foil backed blankets are mainly used to reduce condensation in the roof space, reduce noise from metal roofing and provide a vapour barrier. They are sometimes used as thermal insulation, but it is better to have thicker ceiling insulation for thermal control. Compression of the blanket over the battens lowers the total R-value.

External wall insulation

Insulating your walls saves up to an extra 15% on heating and cooling energy.

Framed walls

Weatherboard walls

The total thermal resistance of typical weatherboard wall construction is approximately R0.45, increasing to R0.9 with RFL insulation. This is insufficient for most building code compliance or sustainability requirements and needs to be supplemented with additional insulation.

Use perforated reflective foil over the outside of the frame. For higher insulation levels, add reflective foil batts between the studs. Make sure that the air space between reflective surfaces is at least 25mm.

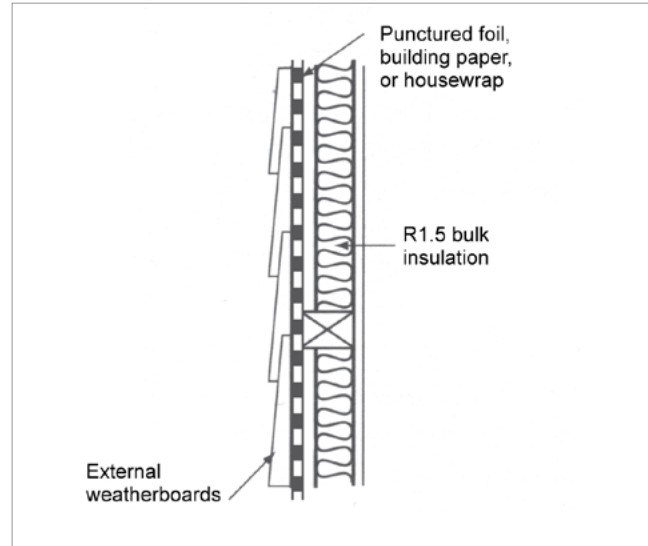

Perforated reflective foil and bulk insulation under weatherboard.

Alternatively, use bulk insulation with perforated building wrap. Ensure batts fit within the cavity without compression, making sure that there is at least a 25mm gap from the reflective surface.

Brick veneer walls

The total thermal resistance of typical brick veneer wall construction is approximately R0.45, increasing to R1.4 with RFL insulation. This is insufficient for most building code compliance or sustainability requirements and needs to be supplemented with additional insulation.

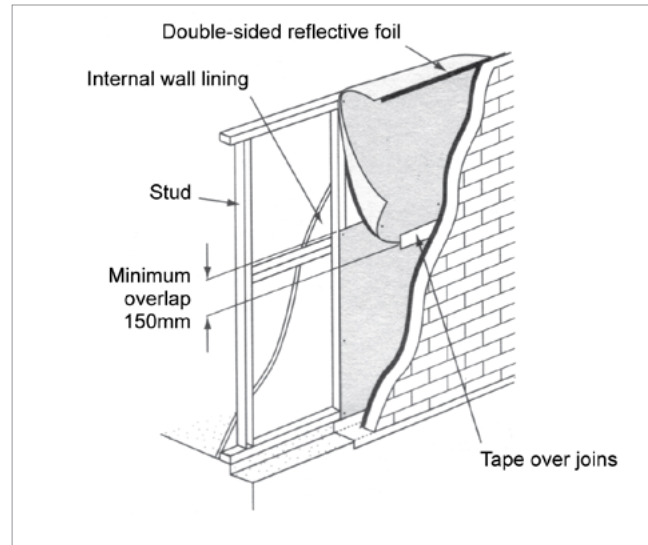

Reflective foil under brick veneer.

For higher insulation levels, add reflective batts between the studs, making sure that air spaces between each reflective surface are at least 25mm. Use bulk insulation with strapping or perforated building wrap over the outside of the frame to prevent batts from touching the porous brick skin.

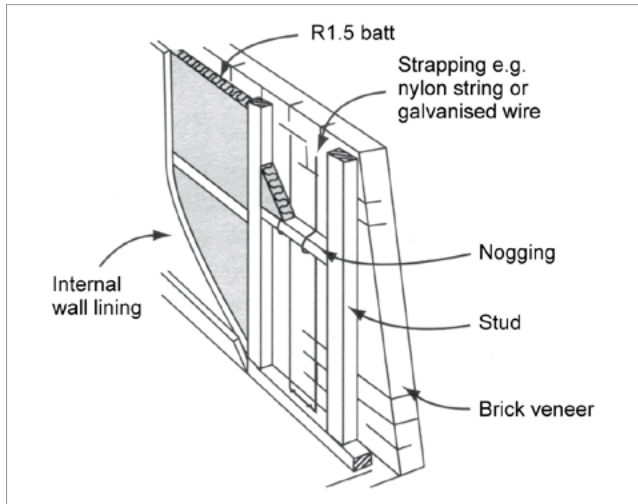

Bulk insulation separated from porous brick skin by strapping.

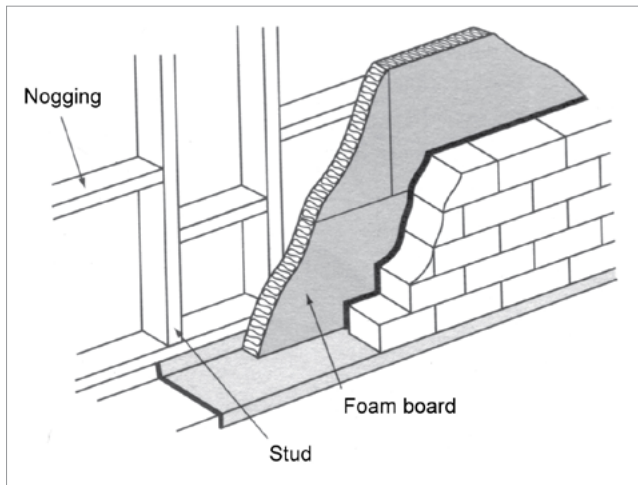

Brick veneer with foam board.

Fixing insulation to the outside of the studs helps reduce thermal bridging in cold climates. Placing the insulation on the outside gives a higher total R-value than placing the insulation between the studs.

Suitable materials include polystyrene boards, high density rockwool batts, and foil faced polystyrene boards with a reflective air space of at least 25mm. Leave sufficient space for bricklayers to lay the outside skin (about 35mm).

Cavity brick walls

The total thermal resistance of typical cavity brick wall construction is approximately R0.5. This is insufficient for most building code compliance or sustainability requirements and needs to be supplemented with additional insulation.

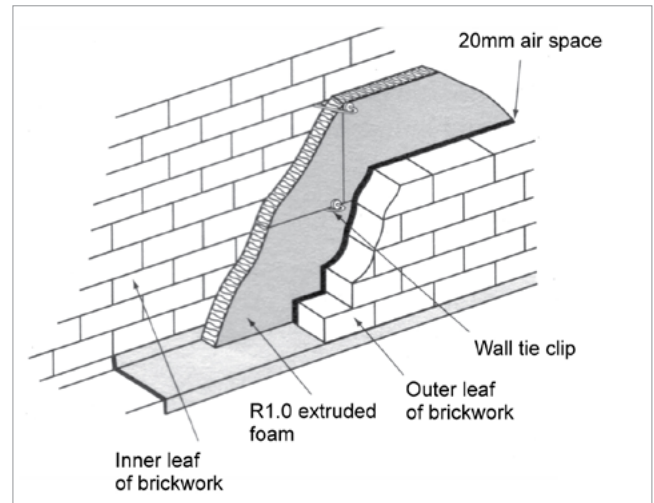

Cavity brick wall with extruded foam.

Use foam boards or cavity fill (loose-fill or injected foams).

Cavity fill insulation is mainly used to insulate existing cavity brick walls. Check that local building regulations allow use of cavity fill. It must be treated to be water repellent. (see *Insulation*)

Foam boards with reflective surfaces do not perform properly if air gaps are not large enough or the reflective surfaces get dirty during construction.

Using cavity fill in double brick walls provides a total R-value of around R1.3 (dependent on cavity width).

Solid walls

Solid walls include concrete block, concrete panel, stone, mud brick, rammed earth (pisé) and solid brick construction without a cavity.

The total thermal resistance of solid wall construction without a cavity is approximately R0.3 to R0.4. This is insufficient for most building code compliance or sustainability requirements and needs to be supplemented with additional insulation.

Solid walls can be insulated on the inside or the outside. Do not insulate the inside of walls whose thermal mass is to be utilised. Insulation isolates the thermal mass from the interior, wasting its beneficial passive heating potential.

Passive design

Insulation installation

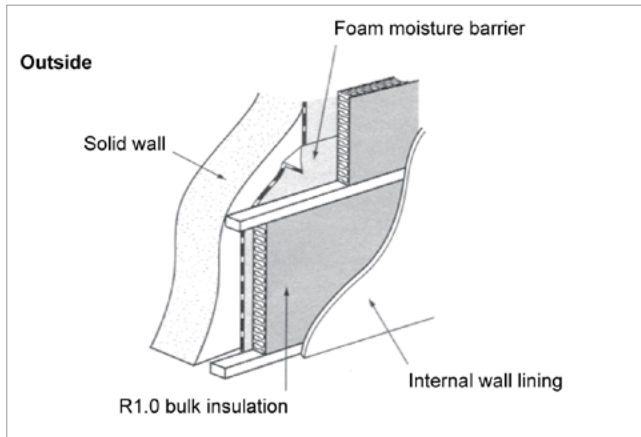

Solid wall with internal foam moisture barrier.

Suitable materials include polystyrene boards, bulk batts, and foil faced foam boards with a still air layer of at least 25mm each side. For internal walls, plasterboard products incorporating polystyrene are also suitable.

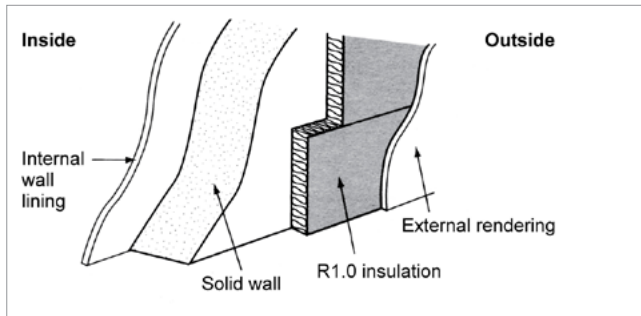

Solid wall with external polystyrene and render.

On external walls, polystyrene can be clad with an external finish, such as render. No additional waterproofing is required. Fix bulk batts between battens and cover with a waterproof cladding.

Floor insulation

Suspended floors

The BCA specifies that a suspended floor, other than an intermediate floor in a building with more than one storey, must achieve a certain R-value for the downwards direction of heat flow for the relevant climate zone. In addition, such a suspended floor with an in-slab heating or cooling system is required to be insulated around the vertical edge of its perimeter and underneath the slab with insulation having an R-value of not less than 1.0.

In cool climates, some mixed climates, and hot climates where air conditioning is used:

- enclose the subfloor space if possible (maintain sufficient ventilation to satisfy local building requirements)
- where appropriate install underlay and carpet, or lay insulation board under floor finishes
- insulate the underside of timber floors or suspended slabs exposed to outside air
- insulate the underside of heated suspended slabs.

Timber floors

The total thermal resistance of typical timber floor construction is approximately R0.3 up and R0.4 down. With RFL insulation it is approximately R0.6 up and R1.0 down. This is insufficient for most building code compliance or sustainability requirements and will require additional insulation.

Use perforated RFL foil or concertina-type batts, stapled to the side of the joists with non-conductive staples.

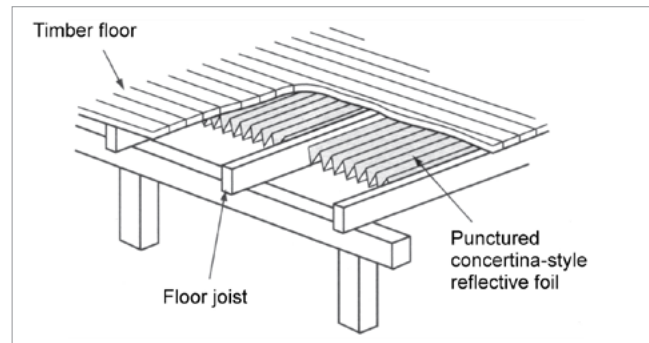

Timber floor with perforated concertina foil.

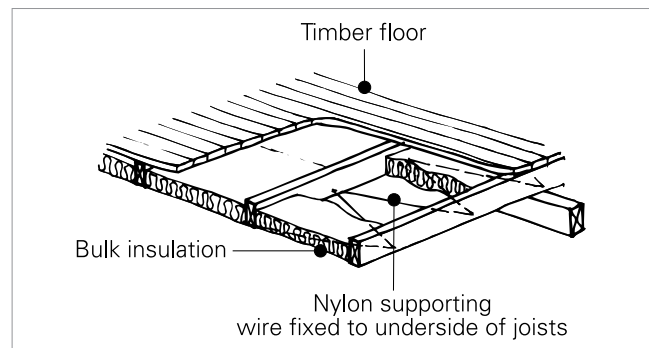

Timber floor with bulk insulation.

Add bulk insulation under the floor, supported by nylon cord or wire as shown.

Suspended concrete slabs

The total thermal resistance of typical suspended concrete floor slab construction is approximately R0.3 up and R0.4 down. This is insufficient for most building code compliance or sustainability requirements and needs additional insulation.

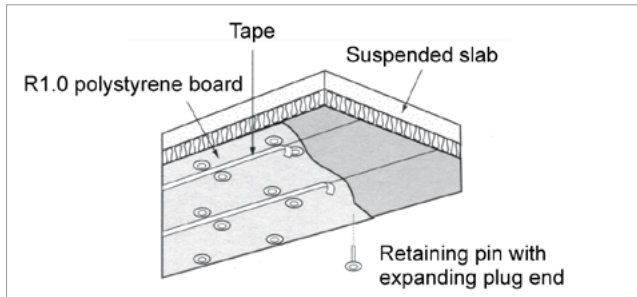

Suspended slab with polystyrene.

Add foam boards or foil faced foam boards. Special fixings should be used with foil faced boards to allow a still air layer between the insulation and the slab.

Slab-on-ground

The BCA specifies that vertical edges of a slab-on-ground must be insulated only if located in climate zone 8 (cold climate) or when in-slab heating or cooling is installed within the slab. (See 3.12.1.5 Floors in BCA 2010, Volume Two.)

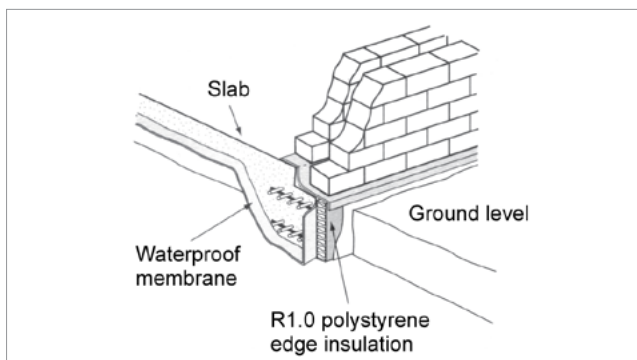

Slab edge insulation.

Slab edge insulation is usually sufficient, as approximately 80% of the heat loss occurs through the edge. Install edge insulation before the slab is poured. Do not install insulation under concrete edge beams.

Follow the manufacturer's directions, particularly regarding the placement of the insulation in relation to the waterproof membrane. In termite prone areas precautions may be needed. Consult your local building information centre.

R1.0 polystyrene boards on the slab edge give a total R-value of at least 2.2 (insulated section only).

For more effective performance, extend an additional fin of polystyrene horizontally from the slab edge as shown.

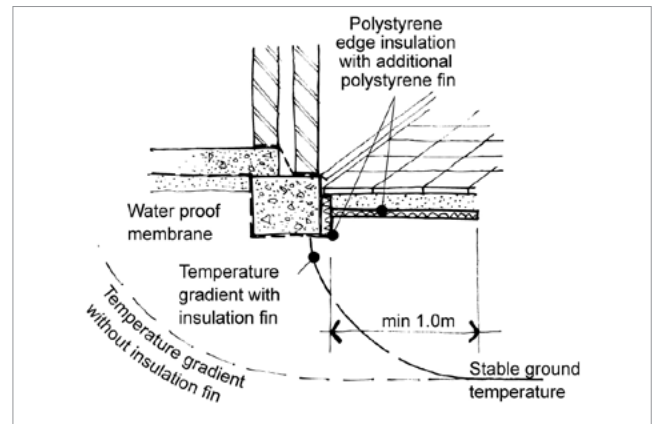

Slab with polystyrene fin.

The fin should extend 1–1.5m and can be laid under external paving. The presence of the fin affects ground temperature gradients, resulting in more stable ground temperatures below the slab.

The fin is easy to install and can be done as a retrofit to existing slabs. It does not interfere with the load carrying capacity of the footings.

Insulate the underside of ground slabs where groundwater is present. This method can also be used in alpine climates and where slab heating is used, although the 'fin' method may be just as effective. Insulation under slabs must have a high compressive strength and be resistant to moisture penetration and rotting. If the material is compressed it no longer acts as an insulator and can even lead to structural failure. Some waffle pods can be used for under-slab insulation, as long as they meet the above criteria.

References and additional reading

ICANZ. 2010. Insulation handbook, Part 1, Thermal performance. icanz.org.au

Sustainable Energy Authority Victoria (SEAV). 2006. Energy smart housing manual, Ch. 7, Insulation. www.aprbuildingservices.com.au

Authors

Principal authors: Max Mosher, Caitlin McGee

Updated by Max Mosher, 2013